



## TECHNICAL BULLETIN

# Yoke Removal and Installation Procedure for Meritor Drive Axles

### Remove the Yoke and Pinion Seal

#### **WARNING**

*Park the vehicle on a level surface. Block the wheels to prevent the vehicle from moving. Support the vehicle with safety stands. Do not work under a vehicle supported only by jacks. Jacks can slip and fall over. Serious personal injury can result.*

#### **CAUTION**

*To prevent serious eye injury, always wear safe eye protection when you perform vehicle maintenance or service.*

1. Park the vehicle on a level surface. Place blocks in front and behind all wheels to prevent the vehicle from moving.
2. Raise the vehicle. Support the vehicle with safety stands.
3. Disconnect the driveline universal joint from the input or output yoke on the differential carrier.
4. Place a yoke bar on the input or output yoke. The yoke bar holds the yoke stationary while you remove the pinion nut. **Figure 1**. To make a yoke bar, refer to "How to Make a Yoke Bar" at the end of this publication.
5. Remove the pinion nut and washer. **Figure 1**.
6. Use a puller tool, as shown in **Figure 2**, to remove the yoke from the carrier.

#### **CAUTION**

*Carefully remove the pinion seal from the yoke or carrier. Do not damage the seal bore when you remove the seal. Damage to components can result.*

7. Use a suitable tool to carefully remove the pinion seal from the carrier. Do not touch or allow dirt or grease to contaminate the sealing surface areas or the adjacent bearings.

Figure 1

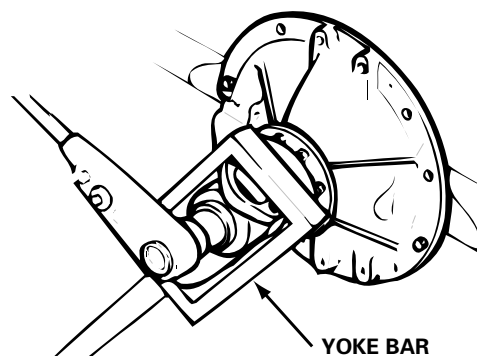
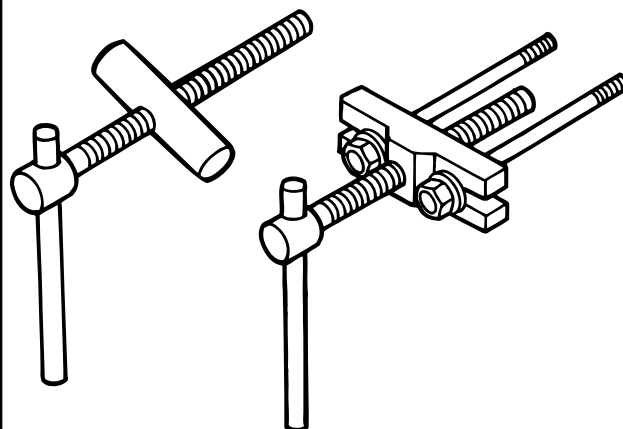

Figure 2



## Install the Unitized Pinion Seal

Three different types of pinion seals are available. **Figure 3.** Meritor recommends that you install a unitized seal when you install a yoke.

- **For installation instructions on triple lip seals with the POSE™ feature:** Refer to Publication No. MM-9674, *Installation of the Driveline POSE™ Seal.*
- **For installation instructions on triple lip seals without the POSE™ feature:** Refer to Maintenance Manual No. 5L, *Single Reduction Forward Differential Carriers on Tandem Axles.*

To order these publications, call Meritor's Customer Service Center at 800-535-5560.

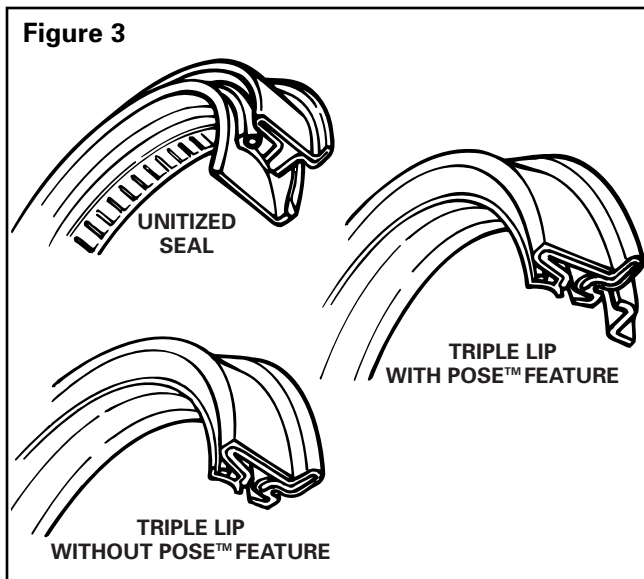

1. Inspect the bearing cage seal area for damage that could cause lubricant leaks after you install the seal. Use emery paper or equivalent to remove scratches, nicks or burrs only.
2. Remove the replacement unitized seal from the package.
3. Select the correct seal driver from **Table A.** Each seal driver is designed to correctly install a specific diameter seal. To determine the yoke seal diameter, measure the yoke journal. Refer to **Table A.**

4. Position the driver and seal. **Figure 4.**

- **If you use the R4422401 driver tool to install a forward tandem axle seal:** The driver tool outer spokes or fins **MUST** fit between the bearing cage bolts. Ensure that the bolts on the bottom of the bearing cage are not in the path of the driver spokes. If the driver spokes contact the bearing cage bolts, the driver will incorrectly install the seal into the bearing cage seat and can also result in damage to the driver. The reference mark on the driver tool must be in the 12 o'clock or the 6 o'clock positions when you install the new seal.

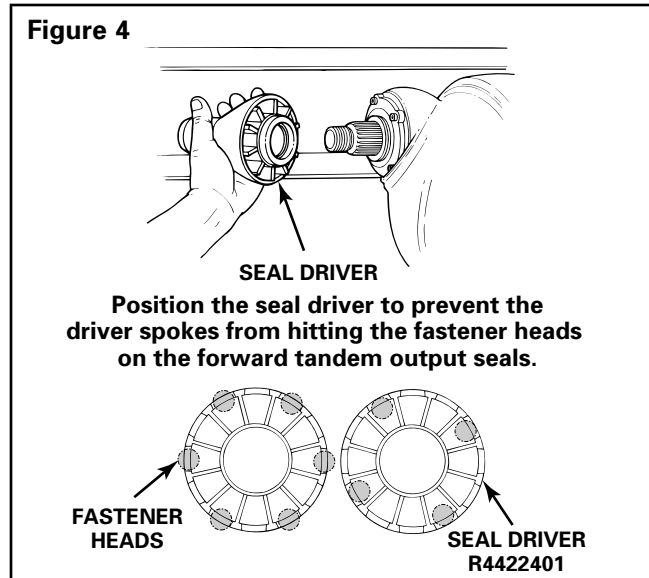

### CAUTION

**Use a rubber mallet to install the seal. Do not use a steel, brass or plastic hammer to install the seal. Using a steel, brass or plastic hammer can damage the seal and driver tool.**

5. Use a rubber mallet to drive the seal into or against the bearing cage. The seal must fully seat into or against the bearing cage. **Figure 5.**

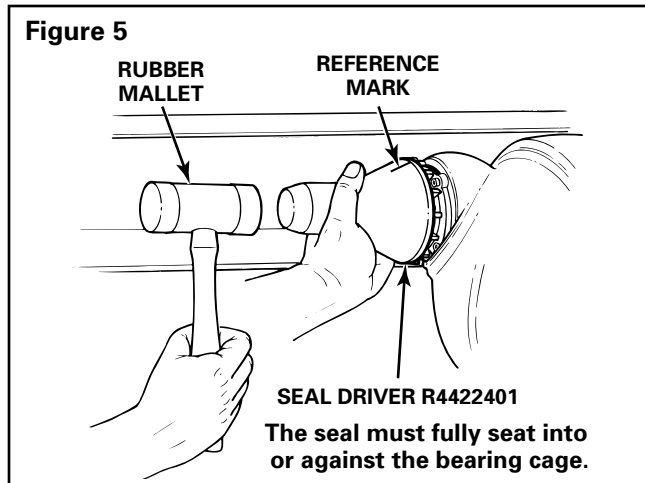

- Use a 0.01-inch shim to check for clearance between the entire seal flange circumference and the bearing cage.
  - If the 0.01-inch shim slides between the seal flange and bearing cage: Correctly position the seal driver and drive the seal into the bore until the 0.01-inch shim cannot slide between the seal flange and bearing cage at any point around the seal flange.

## Clean and Inspect the Yoke

### WARNING

Solvent cleaners can be flammable, poisonous and cause burns. Examples of solvent cleaners are carbon tetrachloride, emulsion-type cleaners and petroleum-based cleaners. To avoid serious personal injury when you use solvent cleaners, you must carefully follow the manufacturer's product instructions and these procedures:

- Wear safe eye protection.
  - Wear clothing that protects your skin.
  - Work in a well-ventilated area.
  - Do not use gasoline, or solvents that contain gasoline. Gasoline can explode.
  - You must use hot solution tanks or alkaline solutions correctly. Follow the manufacturer's instructions carefully.
- Clean the ground and polished surface of the yoke journal using a clean shop towel and a safe cleaning solvent. Do not use gasoline, abrasive cleaners, towels or scrubbers to clean the yoke. Do not attempt to polish the yoke.

**NOTE:** The unitized seal features a rubber inner sleeve that is designed to seal and rotate with the yoke. This feature allows you to reuse a yoke with minor grooves.

- Inspect the yoke seal surface for grooves.
  - If you find grooves on the yoke: Use calipers to measure the groove diameters. If any groove diameter measures less than the dimensions shown in Figure 6, replace the yoke.

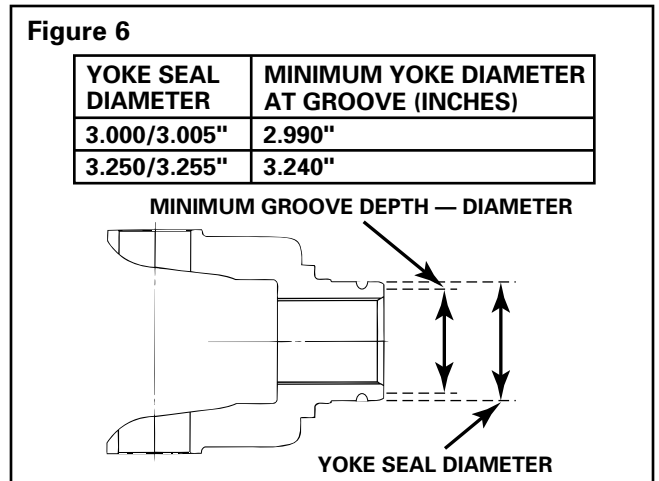

## Install the Yoke

### CAUTION

Do not install a POSE™ seal after you install a unitized pinion seal. The use of a POSE™ seal will prevent correct seating of the unitized pinion seal on the yoke and can result in lubricant leakage at the seal. POSE™ seal installation is recommended only for triple lip and other previous design seals.

Do not use thin metal wear sleeves to refresh the yoke surface. Wear sleeves pressed onto the yoke can prevent correct seating of the pinion seal, damage the pinion seal assembly and can cause the seal to leak.

- Before you install the yoke, lightly lubricate or coat the yoke seal journal with axle oil.
- Align the yoke splines with the shaft splines. Slide the yoke over the shaft spline.

## **WARNING**

Observe all warnings and cautions provided by the press manufacturer to avoid damage to components and serious personal injury.

## **CAUTION**

Use a press and a sleeve or yoke installation tool to install the yoke. Do not use a hammer or mallet to install the yoke. Using a hammer or mallet can damage the bearings, yoke or flange.

After you partially or fully install a yoke and then remove it for any reason, the unitized pinion seal will be damaged and unusable. If the yoke and unitized pinion seal are removed after partial or full installation, remove and discard the original unitized pinion seal and replace it with a new unitized pinion seal. Do not reuse the seal.

If you remove the inner sleeve of the unitized seal, the seal is not usable. A new seal is required. This will occur when a yoke is installed into the seal and removed.

3. Use a press and a sleeve or a yoke installation tool to install the yoke on the input or output shaft. Ensure that the yoke or flange seats against the outer bearing.
  - If you use a press and a sleeve: Support the input or output shaft. **Figure 7.**

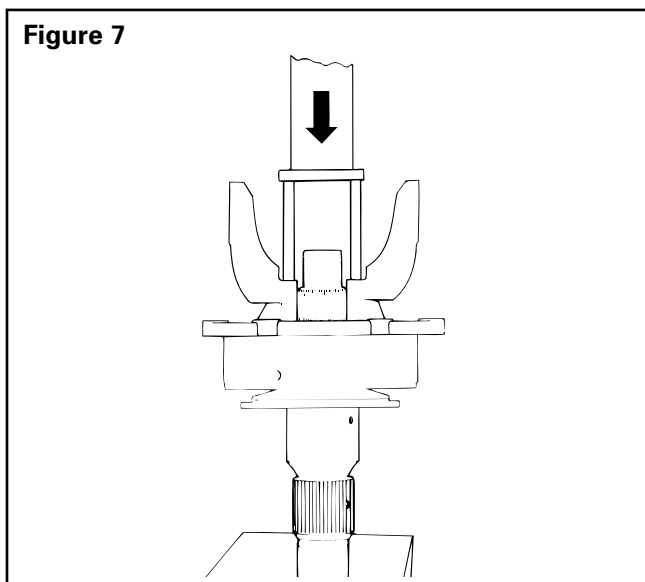

4. Install a new locking pinion nut.
5. Place a yoke bar on the input or output yoke. **Figure 8.**

6. Use a torque multiplier or suitable torque wrench to tighten the pinion nut to the correct torque specification shown in **Table B.** 

**Figure 8**

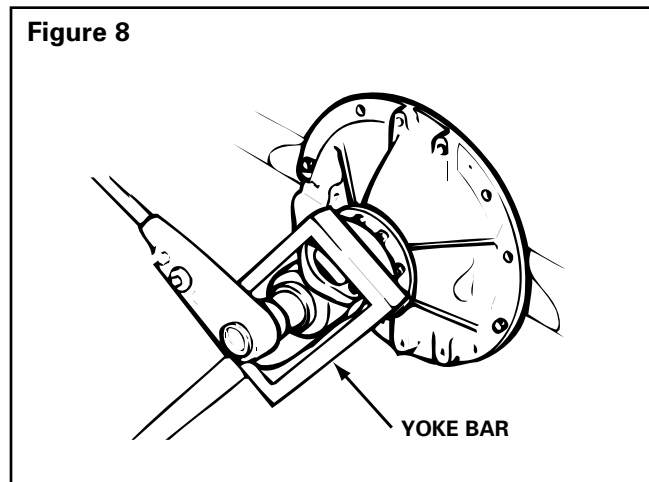

7. Rotate the yoke at least one full turn after you tighten the pinion nut to the correct torque specification to ensure that the seal seats correctly.
8. Connect the driveline universal joint to the input or output yoke on the differential carrier.
9. Remove the safety stands and lower the vehicle.

## **How to Make a Yoke Bar**

1. Measure dimensions "A" and "B" of the yoke you are servicing. **Figure 9.**

**Figure 9**

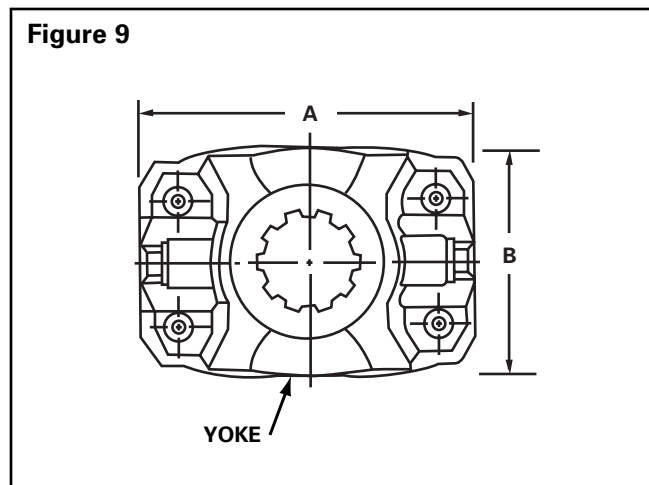

- Calculate dimensions "C and "D" of the yoke bar by adding 0.125-0.250-inch to dimensions "A" and "B" of the yoke. **Figure 10.**

**⚠ WARNING**

*Wear save clothing and eye protection when you use welding equipment. Welding equipment can burn you and cause serious personal injury. Follow the operating instructions and safety procedures recommended by the welding equipment manufacturer.*

- To make the "box" section, cut and weld 1.0-inch x 2.0-inch mild steel square stock according to dimensions "C" and "D." **Figure 10.**
- Cut a 4.0-foot x 1.25-inch piece of mild steel round stock to make the yoke bar handle. Center weld this piece to the "box" section. **Figure 10.**
  - To increase yoke bar rigidity:** Weld two angle pieces onto the handle. **Figure 10.**

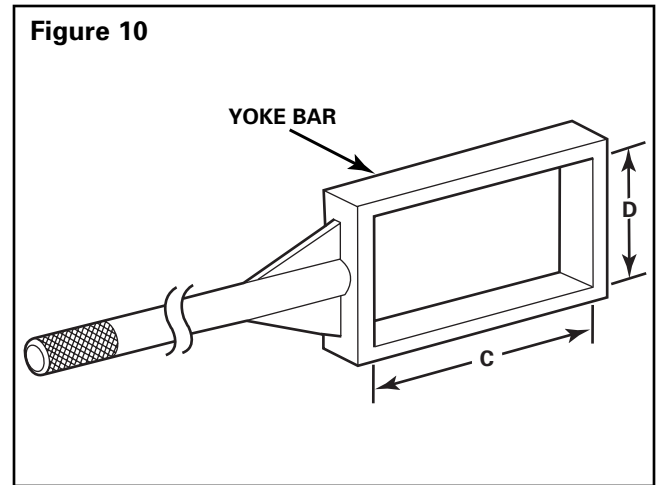

**Table A: Unitized Pinion Seals and Seal Drivers**

Single Models	Tandem Models	Meritor Unitized Pinion Seal	Seal Installation Location	Meritor Seal Driver	Yoke Seal Diameter Inches
RS-17-145 RS-19-145 RS-21-145	RT-34-144 /P RT-34-145 /P RT-40-145 /A /P	A-1205-R-2592	Tandem Forward Input (145 models from 11-93 to present)	R4422402	3.250 3.255
RS-21-160 RS-23-160 /A RS-23-161 /A RS-25-160 /A	RT-40-149 /A /P RT-44-145 /P RT-40-160 /A /P RT-40-169 /A /P	A-1205-P-2590	Tandem Forward Output (Tandem Forward Input 145 models before 11/93 with seal A-1205-F-2424)	R4422401	3.000 3.005
RS-23-186 RS-26-185 RS-30-185	RT-46-160 /A /P RT-46-169 /A /P RT-46-164EH /P RT-46-16HEH /P RT-50-160 /P RT-52-185* RT-58-185*	A-1205-N-2588	Tandem and Single Rear Input (145 models)	R4422401	3.000 3.005
		A-1205-Q-2591	Tandem and Single Rear Input (160/164/185 models)	R4422402	3.250 3.255

To order Meritor seal driver KIT 4454, call 888-725-9355.

\*Forward and rear input only.

**Table B: Input and Output Yoke Pinion Nut Fastener Torque Specifications**

**Single Axles**

<b>Axle Model</b> <b>Pinion Nut Location</b>	<b>RS-120, RS-125, RS-140</b>	<b>RS-145</b>	<b>RS-160, RS-161, RS-185, RS-186</b>	<b>RS-210, RS-220, RS-230</b>	<b>RS-240</b>	<b>RS-380</b>
<b>First Carrier Input Yoke</b>	740-920 lb-ft (1000-1245 N•m) Fastener Size: M32 X 1.5	920-1130 lb-ft (1250-1535 N•m) Fastener Size: M39 X 1.5	1000-1230 lb-ft (1350-1670 N•m) Fastener Size: M45 X 1.5	740-920 lb-ft (1000-1245 N•m) Fastener Size: M32 X 1.5	740-920 lb-ft (1000-1245 N•m) Fastener Size: M39 X 1.5	800-1100 lb-ft (1085-1496 N•m) Fastener Size: 1-1/2 - 12 UNF

**Tandem Axles**

<b>Axle Model</b> <b>Pinion Nut Location</b>	<b>RT-140</b>	<b>RT-145, RT-149</b>	<b>RT-160, RT-164, RT-169</b>	<b>RT-180, RT-185</b>	<b>RT-380 With IAD</b>	<b>RT-380 Without IAD</b>
<b>First Carrier Input Yoke</b>	600-800 lb-ft (815-1085 N•m) Fastener Size: M45 X 1.5	600-800 lb-ft (815-1085 N•m) Fastener Size: M45 X 1.5	600-800 lb-ft (815-1085 N•m) Fastener Size: M45 X 1.5	600-800 lb-ft (815-1085 N•m) Fastener Size: 1-3/4 - 12 UN	600-800 lb-ft (815-1085 N•m) Fastener Size: 1-3/4 - 12 UN	900-1200 lb-ft (1224-1632 N•m) Fastener Size: 1-3/4 - 12 UN
<b>First Carrier Output Yoke</b>	450-650 lb-ft (610-880 N•m) Fastener Size: M32 X 1.5	450-650 lb-ft (610-880 N•m) Fastener Size: M39 X 1.5	450-650 lb-ft (610-880 N•m) Fastener Size: M39 X 1.5	450-650 lb-ft (610-880 N•m) Fastener Size: 1-1/2 - 12 UNF	450-650 lb-ft (610-880 N•m) Fastener Size: 1-1/2 - 12 UNF	450-650 lb-ft (610-880 N•m) Fastener Size: 1-1/2 - 12 UNF
<b>Second Carrier Input Yoke</b>	740-920 lb-ft (1000-1245 N•m) Fastener Size: M32 X 1.5	920-1130 lb-ft (1250-1535 N•m) Fastener Size: M39 X 1.5	1000-1230 lb-ft (1350-1670 N•m) Fastener Size: M45 X 1.5	1000-1230 lb-ft (1350-1670 N•m) Fastener Size: M45 X 1.5	800-1100 lb-ft (1085-1496 N•m) Fastener Size: 1-1/2 - 12 UNF	800-1100 lb-ft (1085-1496 N•m) Fastener Size: 1-1/2 - 12 UNF

**Tridem Axles**

<b>Axle Model</b> <b>Pinion Nut Location</b>	<b>RZ-164</b>	<b>RZ-166</b>	<b>RZ-186</b>	<b>RZ-188</b>
<b>First Carrier Input Yoke</b>	600-800 lb-ft (815-1085 N•m) Fastener Size: M45 X 1.5	600-800 lb-ft (815-1085 N•m) Fastener Size: M45 X 1.5	600-800 lb-ft (815-1085 N•m) Fastener Size: 1-3/4 - 12 UN	600-800 lb-ft (815-1085 N•m) Fastener Size: 1-3/4 - 12 UN
<b>First Carrier Output Yoke</b>	450-650 lb-ft (610-880 N•m) Fastener Size: M39 X 1.5	450-650 lb-ft (610-880 N•m) Fastener Size: M39 X 1.5	450-650 lb-ft (610-880 N•m) Fastener Size: 1-1/2 - 12 UNF	450-650 lb-ft (610-880 N•m) Fastener Size: 1-1/2 - 12 UNF
<b>Second Carrier Input Yoke</b>	600-800 lb-ft (815-1085 N•m) Fastener Size: M45 X 1.5	600-800 lb-ft (815-1085 N•m) Fastener Size: M45 X 1.5	600-800 lb-ft (815-1085 N•m) Fastener Size: M45 X 1.5	600-800 lb-ft (815-1085 N•m) Fastener Size: 1-3/4 - 12 UN
<b>Second Carrier Output Yoke</b>	450-650 lb-ft (610-880 N•m) Fastener Size: M39 X 1.5	450-650 lb-ft (610-880 N•m) Fastener Size: M39 X 1.5	450-650 lb-ft (610-880 N•m) Fastener Size: M39 X 1.5	450-650 lb-ft (610-880 N•m) Fastener Size: 1-1/2 - 12 UNF
<b>Third Carrier Input Yoke</b>	920-1130 lb-ft (1250-1535 N•m) Fastener Size: M39 X 1.5	1000-1230 lb-ft (1350-1670 N•m) Fastener Size: M45 X 1.5	1000-1230 lb-ft (1350-1670 N•m) Fastener Size: M45 X 1.5	1000-1230 lb-ft (1350-1670 N•m) Fastener Size: M45 X 1.5





**Meritor Heavy Vehicle Systems, LLC**  
2135 West Maple Road  
Troy, MI 48084 USA  
800-535-5560  
[www.meritorauto.com](http://www.meritorauto.com)

Information contained in this publication was in effect at the time the publication was approved for printing and is subject to change without notice or liability. Meritor Heavy Vehicle Systems, LLC, reserves the right to revise the information presented or discontinue the production of parts described at any time.

© Copyright 1999  
Meritor Automotive, Inc.  
All Rights Reserved

Printed in the USA

TP-2001  
Issued 11-99  
16579/Meritor