

# PX309 Series Accessories



DP8PT, shown smaller than actual size.



CA-359-4PC22-2M cable, shown smaller than actual size.

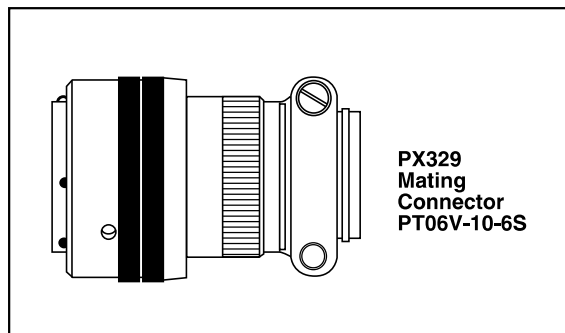

PX329 Mating Connector PT06V-10-6S

## Accessories

Model No.	Description
CAL-3	Recalibration with 5 point NIST traceable documentation
PT06V-10-6S	Mating connector for PX329
CA-329-4PC24-005	4-conductor mating twist-lock 6 pin connector with 1.5 m (5') cable for PX329
CX5302	Extra mini DIN connector for PX319
CA-359-4PC22-2M	2 m (6') vented cable with M12 connector for PX359 for gage ranges <100 psi
CA-359-4PC22-5M	5 m (16') vented cable with M12 connector for PX359 for gage ranges <100 psi
M12C-PVC-4-S-F-5	5 m (16') PVC cable, straight 4-pin M12 female connector one end, flying leads one end, for all PX359 absolute ranges and gage ranges >100 psi
DP8PT	4-digit meter for both mV/V and amplified PX3*9 models
DP25B-S	4-digit strain meter for mV/V PX3*9 models
DP25B-E	4-digit process meter for amplified PX3*9 models

Note: Complete meter specifications can be found at OMEGA.